

12/12/2011

**Mercury Vapor
250 Watt ED28 (Clear) Lamp**

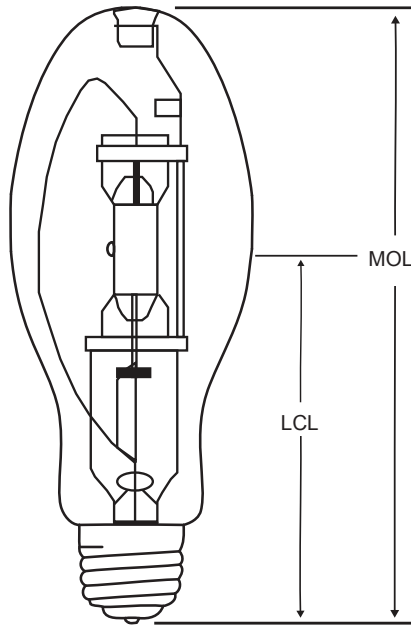

Project:	
Catalog#:	
Approved by:	

Ordering Information	
Howard Catalog Number (Ordering Code)	H37KB-250
UPC Code	01157
ANSI Designation	H37
Description	Mercury Vapor
Package Quantity	12
Physical Characteristics	
Bulb Size	ED28
Bulb Finish	Clear
Base	Mogul
MOL (Maximum Overall Length) (in.)	8.25
LCL (Light Center Length) (in.)	5
Operating Characteristics	
Lamp Watts (Nominal)	250
Approx. Initial Lumens	11,200
Approx. Mean Lumens	8,400
Average Rated Life (Hours)	10,000+
Color Temperature (K)	4,500
CRI (Color Rendering Index)	20
Operating Position	
Universal	

Note:

- WARNING: THIS LAMP CAN CAUSE SERIOUS SKIN AND EYE INFLAMMATION FROM SHORT WAVE ULTRAVIOLET RADIATION IF THE OUTER ENVELOPE OF THE LAMP IS BROKEN OR PUNCTURED. DO NOT USE WHERE PEOPLE WILL REMAIN FOR MORE THAN A FEW MINUTES UNLESS ADEQUATE SHIELDING OR OTHER SAFETY PRECAUTIONS ARE USED.** Lamps that will automatically extinguish when the outer envelope is broken or punctured are commercially available.
- This product conforms to the following federal regulations: USA: 21CFR 1040.30 and CANADA: SOR/80-381.
- Electrical Shock and Burn Hazard:** Do not remove or insert lamp when power is on. If outer glass bulb is broken, shut off power immediately and remove lamp after it has cooled.
- Protect lamp from direct contact with liquids to avoid breakage from thermal shock.
- This lamp must be used only with proper circuit and auxiliary equipment and suitable ballast.
- Do not scratch the glass of bulb or subject this lamp to undue pressure as either may cause lamp to break. Replace scratched, cracked, broken or damaged bulbs immediately.
- The lamp should be screwed firmly, but not forcibly, into the socket to reduce the possibility of loosening due to vibration. Use of excessive force may result in lamp breakage.
- Do not touch hot lamps with fingers, skin or any flammable material. Lamps may remain hot after being turned off.
- Keep combustible materials away from lamp during operation.
- Do not paint the lamp to prevent its overheating or breakage.
- This is a discharge lamp and requires some time to restart and come up to full brightness after a power interruption. If power supply dips or is interrupted, lamps may extinguish and not restart. Turn off power supply for 10-15 minutes and allow lamp to fully cool. Lamp will restart when power is restored.
- LAMP CONTAINS MERCURY**, manage in accordance with local, state, and federal disposal laws. See: www.lamprecycle.org.
- Specifications subject to change. Actual results may vary.